

VAL-MATIC®

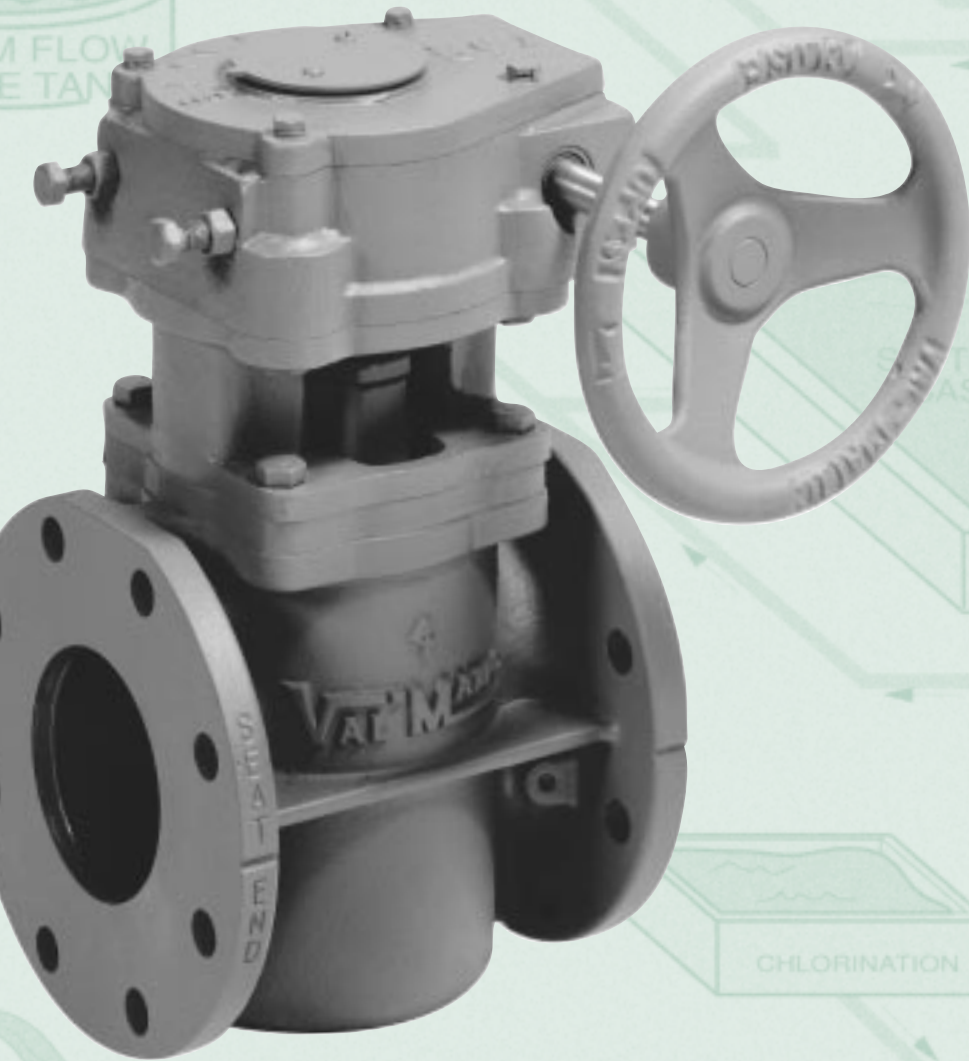

**TRADITIONAL
FEATURES**

**ADVANCED
TECHNOLOGY**

EFFLUENT



**TRADITIONAL
FEATURES**

■
**ADVANCED
TECHNOLOGY**

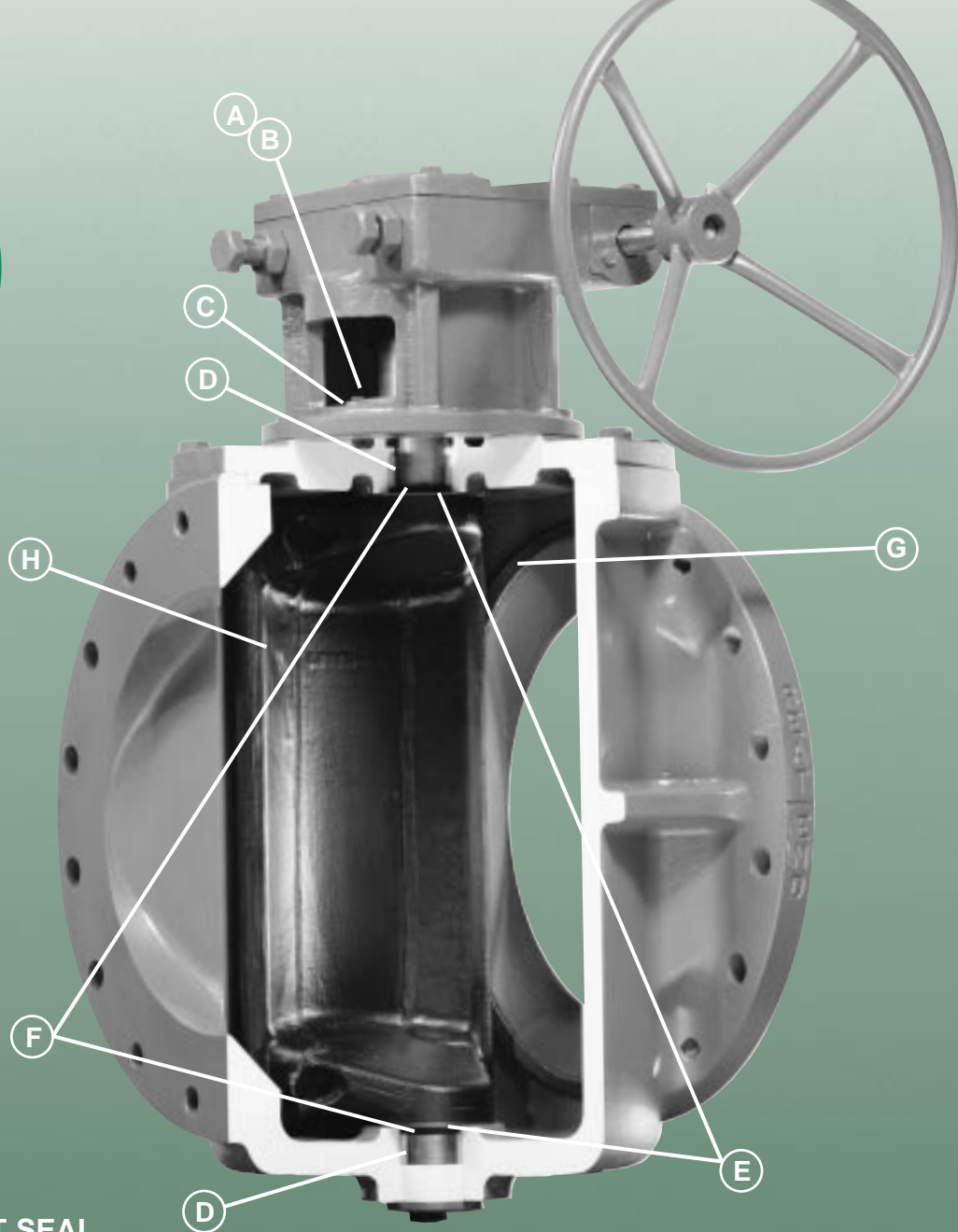

**VAL-MATIC® SHAFT SEAL
SYSTEM WITH EXCLUSIVE
POP™ SHIMS (PACKING
OVERLOAD PROTECTION)**

- A. ADJUSTABLE PACKING FOLLOWER**
Meets recommended requirements for adjustment of Vee type packing.
- B. VEE TYPE PACKING**
Field adjustable and replaceable without removal of actuator.
- C. REMOVABLE POP™ SHIMS**
Packing Overload Protection Shims protect packing by preventing overloading by field personnel. (Patent applied for)

**VAL-MATIC®
BEARING PACKAGE**

- D. RADIAL BEARINGS**
Heavy Duty, Stainless Steel, Permanently Lubricated.
- E. THRUST BEARING**
Lower: Stainless Steel
Upper: Teflon®

**VAL-MATIC® GRIT-GUARD™
BEARING AND PACKING
PROTECTOR**

- F. A VAL-MATIC® EXCLUSIVE**
The Grit-Guard™ shaft seal extends packing and bearing life by minimizing contact with line media.

**VAL-MATIC®
SEATING SYSTEM**

*Performance Enhanced
Technology*

- G. SEAT**
Welded overlay of 99% pure nickel applied directly to the body using a state-of-the art robotic welding system for a consistent, high quality weld. (2 1/2" and larger)
- H. PLUG**
Resilient facing formulated by Val-Matic® and leading industry rubber experts to assure a tight seal and long life.

Teflon is a registered trademark of DuPont.

Technical papers discussing the technical enhancements of the Val-Matic® seating and shaft seal systems is available. Please contact Val-Matic® for complimentary copies.

WHY AN ECCENTRIC PLUG VALVE?

Installed in thousands of applications the world over, the eccentric plug valve has proven itself as the valve of choice in wastewater and water applications. Unlike a multi-turn gate valve, the eccentric plug valve is a 1/4 turn valve allowing cost effective, low torque actuation for shut-off and throttling service. And while the gate valve leaves its operating stem exposed to the flow, the plug valve shaft and gear are both removed from the flow and protected from the media. Slurries and sewage are easily handled without clogging and with minimal headloss due to the valves linear flow path. The valve's eccentric action rotates the plug in and out of the seat without scraping or binding. The combination of the eccentric action and heavy duty nickel seat assures long life with minimal maintenance.

WHY CAM-CENTRIC?

TRADITIONAL FEATURES...

of the Cam-Centric include the features engineers and operators have come to expect in a plug valve. Adjustable and replaceable Vee-Type packing is standard as are stainless steel, permanently lubricated radial bearings and a welded nickel seat. Val-Matic has been able to enhance the performance of these features through

...ADVANCED TECHNOLOGY

By incorporating the latest in design, material and manufacturing technologies, Val-Matic has significantly improved upon these time proven features.

SHAFT SEAL SYSTEM

Vee-Type packing leaks for two reasons. It's worn, or the gland follower has been over tightened destroying the packing's sealing capabilities. Val-Matic has enhanced the traditional design of Vee-Type packing systems to reduce wear and prevent over tightening of the follower.

Wear is reduced by the Grit-Guard™ seal which prevents grit, the prime cause of wear, from reaching the

bearings and packing. The seals are supplied standard in both the upper and lower journals. (Figure 1 & 2)

To prevent the packing from being over tightened, the shaft seal incorporates POP™ (Packing Overload Protection) Shims. Adjustment is easily accomplished by removing shims as necessary by utilizing the pull tab feature. (Figure 1) Any minimal maintenance required to the Cam-Centric shaft seal can be done without removal of the actuator. This includes removal/ replacement of the packing as well as removal of shims. The shaft seal fully complies with ANSI/AWWA C504.

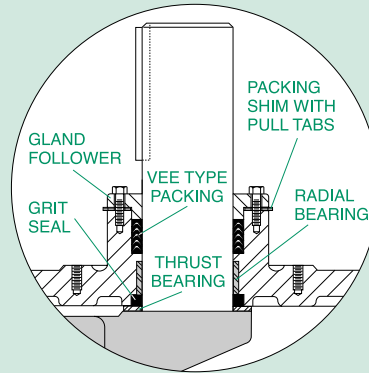

Figure 1: Upper Bearing Journal

CAM-CENTRIC BEARING PACKAGE

The Cam-Centric bearing package consists of T316 stainless steel, permanently lubricated Radial Bearings in both the upper and lower journals. Thrust bearing of Teflon (upper journal) and T316 Stainless Steel (lower journal) are also provided. Like the packing, the bearings are protected from grit related wear by the Grit-Guard™ grit seal. (Figure 1 & 2)

CAM-CENTRIC SEATING SYSTEM

The Cam-Centric utilizes a resilient faced plug formulated by Val-Matic

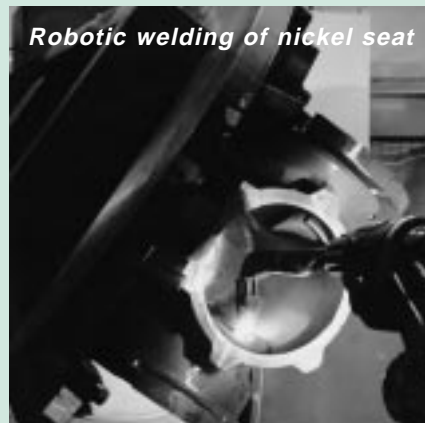

in conjunction with leading industry rubber experts to assure a tight seal and long life. Its mating surface, the nickel seat is applied directly to a machined surface on the valve body using a state-of-the-art robotic welding system for a consistent, high quality weld.

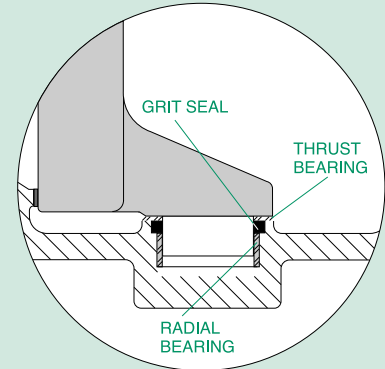

Figure 2: Lower Bearing Journal

PROOF OF DESIGN TESTING

The Cam-Centric has been subjected to rigorous testing per the requirements of ANSI/AWWA C504. All valve and actuation tests were third party witnessed and were successfully completed. Copies of the test reports are available from Val-Matic.

INCREASED PORT AREA FOR INCREASED FLOW

Cam-Centric® plug valves are designed to provide low headloss to maximize flow and reduce operating costs. 100% port areas are standard on valves 4" and smaller, optional on valves 6" and larger. Standard port areas for 6" and larger valves are larger than traditional rectangular ported valves.

A WORD ABOUT ANSI/AWWA COMPLIANCE

While most plug valve shaft seal and testing specifications refer to ANSI/AWWA C504, it should be remembered that C504 is a butterfly valve standard written for rubber seated butterfly valves for use in raw or potable water service. It was not written for plug valves, nor was it written for untreated wastewater to which plug valves are typically subjected. The reason the plug valve exists is because other valves, like the butterfly, are unable to handle solids bearing flow. For this reason, it is suggested that the specifier look at the requirements of ANSI/AWWA C504 as minimal requirements. Specify a valve that not only meets the requirements of C504 but exceeds them.

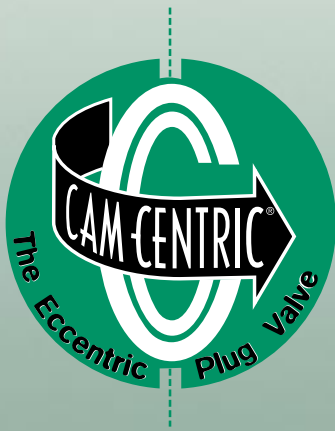

**TRADITIONAL
FEATURES**

■
**ADVANCED
TECHNOLOGY**

**VAL-MATIC® CAM-CENTRIC
WORM GEAR ACTUATOR**

*A QUALITY GEAR FOR A
QUALITY VALVE*

A valve actuator must be able to perform to the same level as the valve. The Cam-Centric worm gear is designed and built to provide the same long term service as the Cam-Centric Valve. The exclusive bearing package in the Cam-Centric worm gear includes four bronze sleeve bearings and two roller thrust bearings. This exclusive package assures smooth operation and long life regardless of the valve's orientation or application. The ductile iron segment gear coupled with upper and lower bronze radial bearings exceeds the requirements of AWWA C504 for strength and durability. All worm gears are designed to exceed, without damage, a rim pull of 200 pounds on handwheels and input torques of 300 foot pounds for operator nuts. Buried service worm gears are grease packed and

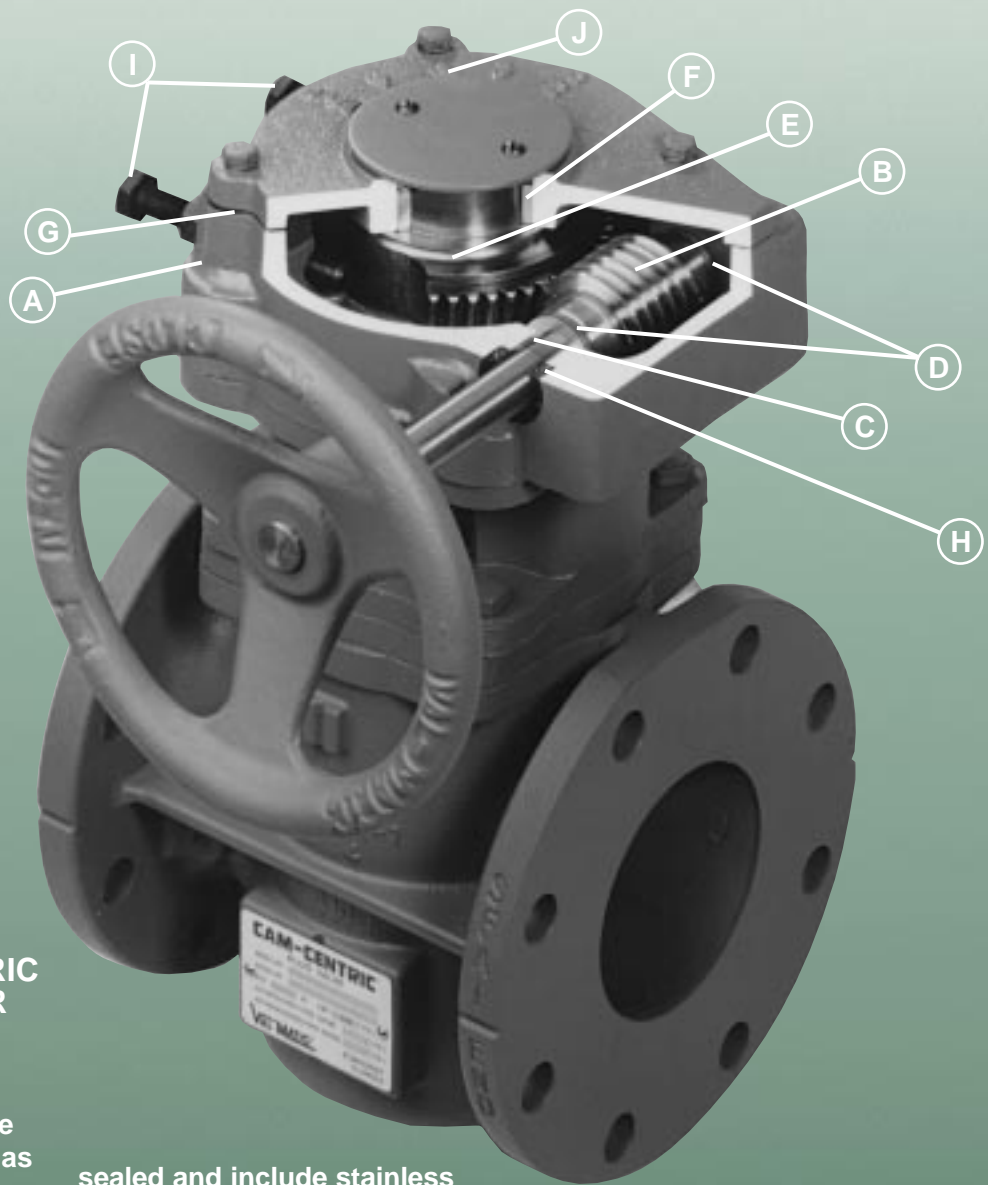

sealed and include stainless steel shafts. Worm gears can be provided with handwheels, chainwheels or 2" operator nuts.

- A. HOUSING**
Heavy duty, totally enclosed and sealed.
- B. WORM**
Hardened steel for durability and long life
- C. RADIAL SHAFT BEARINGS**
Bronze shaft bearings extend life and provide ease of operation (rear shaft bearing not visible).
- D. ROLLER THRUST BEARINGS**
Provides smooth operation and extends life.
- E. SEGMENT GEAR**
Heavy duty ductile iron for high strength. Provided with precision bore and keyway for connection to the valve shaft in multiple positions.
- F. SEGMENT GEAR RADIAL BEARINGS**
Upper and lower bronze bearings provide ease of operation and extend life (lower bearing not visible).
- G. COVER GASKET**
Seals housing and prevents foreign matter from entering valve.
- H. SHAFT SEAL**
Prevents foreign matter from entering the valve.
- I. EXTERNAL STOPS**
Both open and closed stops are adjustable without removal of the valve cover.
- J. POSITION INDICATOR**
Above ground only

ACTUATORS

The Cam-Centric is available with a wide range of actuation options. From pump check to lever operated, Val-Matic is well prepared to meet your specification requirements. Options include 2" operator nuts, worm gears, chain wheels, electric and cylinder actuation. A wide variety of mounting options such as floor stands and extension bonnets are also available

(see accessories on page 7). Val-Matic Engineering personnel meet on a regular basis with cylinder and electric actuation manufacturers to assure actuator/valve compatibility. This helps assure the actuator you specify will deliver the performance you expect when coupled with a Cam-Centric Plug Valve.

Direct nut operated valve with memory stop:

- Use with tee handles, levers, chain handles and extension stems. Supplied standard with memory stop for HVAC applications.



Electric Actuation Including:

- 110 Single Phase, 230/460 Three Phase
- Compliance with AWWA C540 for Power Actuation
- Modulating Service
- Throttling Service
- Remote push button control and indication
- Torque Switches, Limit Switches
- De-clutchable hand wheels



Val-Matic Worm Gears:

- Heavy Duty, totally enclosed and sealed
- Designed and built by Val-Matic
- For above ground and buried service applications
- Bronze radial bearings and roller thrust bearings provide smooth operations and extended life



Cylinder Actuation Including:

- Pneumatic/Hydraulic
- Air/Oil
- Single Acting or Double Acting
- Fail Open/Closed for power failure
- Modulating Service
- Throttling Service
- Limit Switches, Solenoid Valves, Positioners
- Manual Overrides
- Pump Check

FLOW CHARACTERISTICS

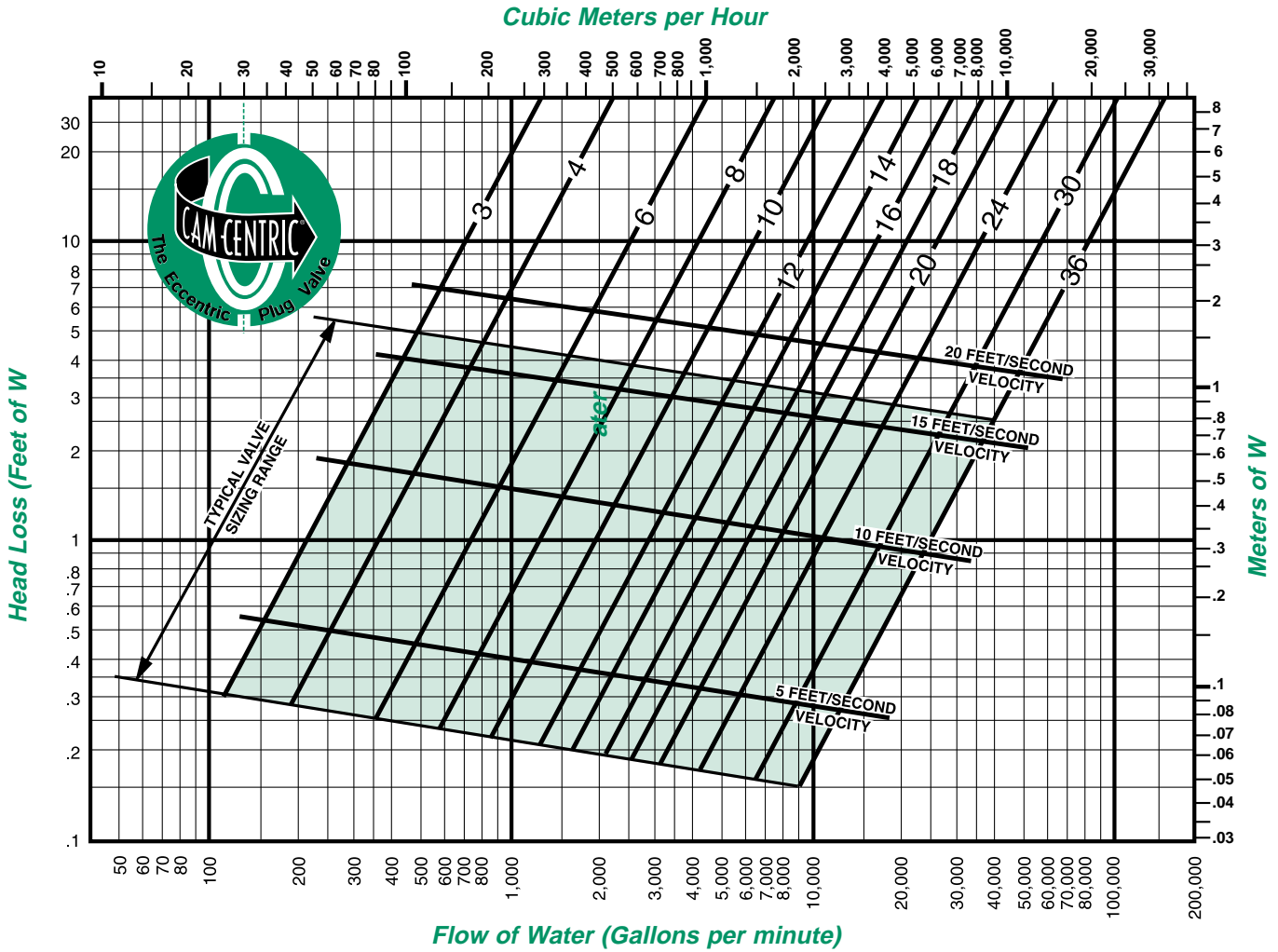

FLOW COEFFICIENTS															
Valve Size	1"	2"	3"	4"	6"	8"	10"	12"	14"	16"	18"	20"	24"	30"	36"
C_V^*	37	150	320	570	1,200	2,070	3,250	4,750	6,150	8,050	10,200	12,600	18,100	28,300	40,700

* C_V = the number of U.S. Gallons/Minute of 60° F water that will flow through the valve with a 1 psi pressure drop.

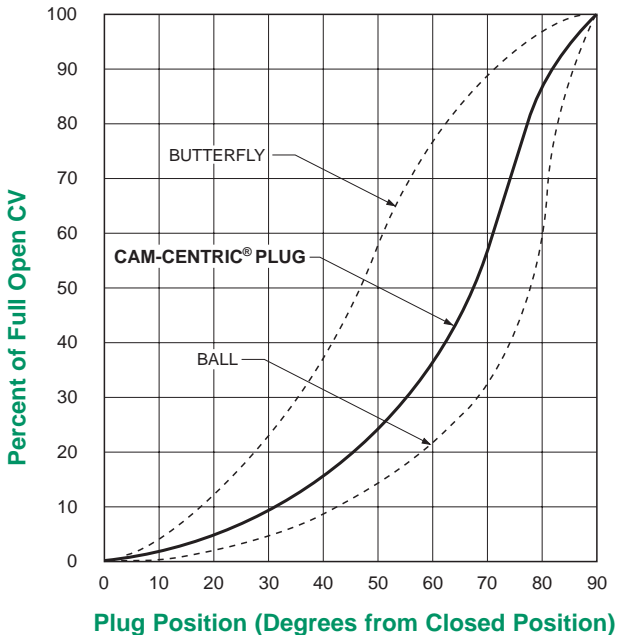

INHERENT FLOW CHARACTERISTICS

To control pressure surges and provide good controllability, the flow characteristics of valves should be considered.

The graph at left shows the inherent flow characteristics at a constant ΔP for various valves.

The Plug valve has an inherent flow characteristic similar to a ball valve. When installed in a pipeline, the plug valve will approximate a linear flow characteristic because the piping system pressure losses will shift the flow curve to the left. A linear installed flow characteristic will help control surges and provide a wide range of controllability.

MATERIALS OF CONSTRUCTION PRESSURE/TEMPERATURE RATINGS

MATERIALS OF CONSTRUCTION	
COMPONENT	STANDARD
Body, Cover and Plug	Cast Iron ASTM A126 Class B
Seating Surfaces	*Welded Nickel Overlay Resilient Plug Facing
Exterior Coating	Universal Primer

NOTE: Val-Matic offers a variety of optional materials, coatings and linings. Please consult factory for available options.
*2-1/2" and larger.

MAXIMUM NON-SHOCK PRESSURE-TEMPERATURE RATING, PSIG		
TEMPERATURE °F / VALVE SIZE	1" - 12"	14" - 36"
100	175	150
150	175	150
200	150	135
Hydrostatic Test Pressure	263	225

NOTES:

- Above ratings are valve ratings. Actuator ratings (shut-off differential pressure) are included under Valve Dimensions and Actuator Selection on page 9.
- Gas service applications require a worm gear, cylinder or power actuator. Valve orders for gas service should specify the application.
- Worm gear actuation is recommended for all buried service valves.

ACCESSORIES

Space limitations and applications such as submerged service often require special accessories. In addition to those shown below, Val-Matic offers a wide range of

accessories to meet your application requirements. Please consult the factory for assistance.

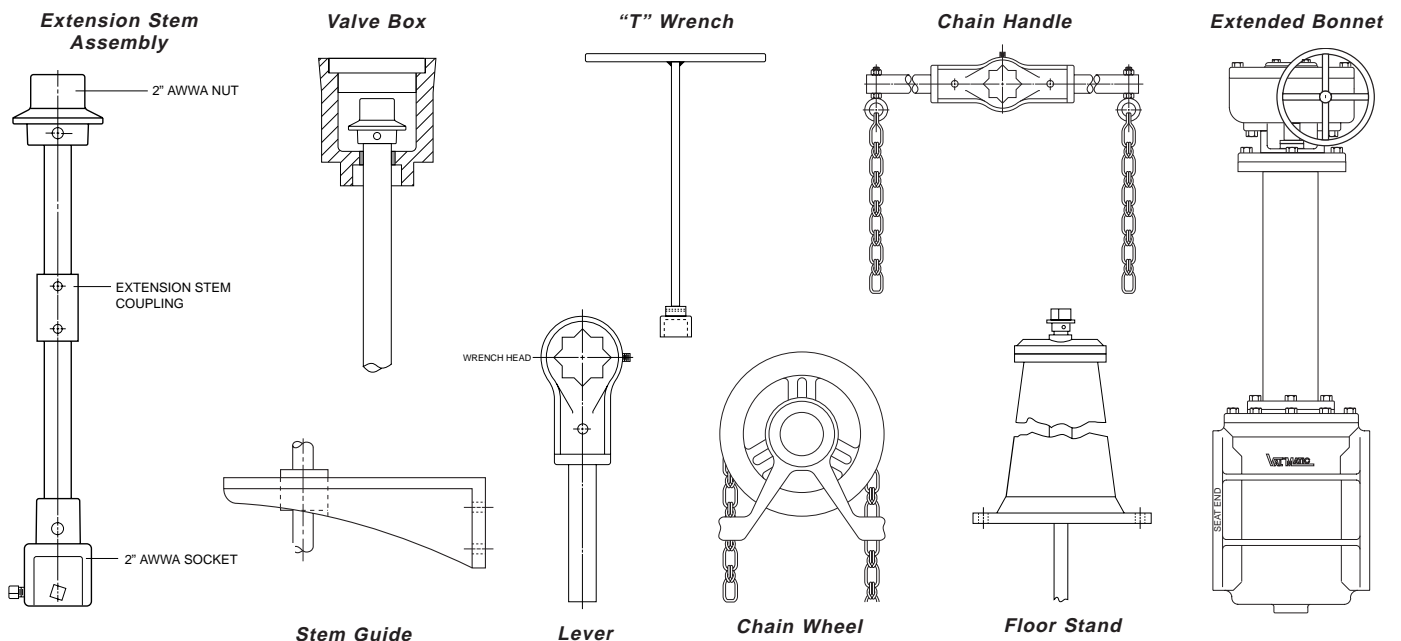

APPLICATIONS / FEATURES



18" Cam-Centric® plug valve with motor actuator.

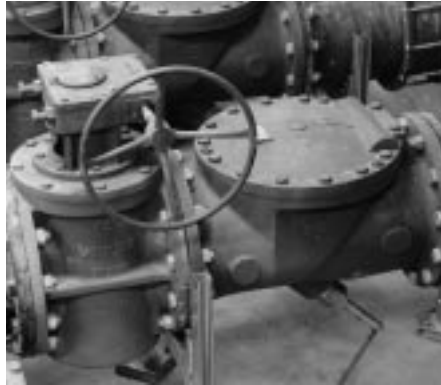

14" Cam-Centric® plug valve with Val-Matic® Swing-Flex® Check Valve.



20" and 16" Cam-Centric® plug valves with worm gears and motor actuators.



18" motor actuated Cam-Centric® plug valve.



16" Cam-Centric® plug valve with extension stem and motor actuator.



16" Cam-Centric® plug valve. Cylinder actuated with hydraulic, manual override.

APPLICATIONS

Potable Water	✓	Sludge	✓
Raw Water	✓	Primary Effluent	✓
Secondary Wastewater Effluent	✓	Salt Water, Sea Water, Brine, Brackish Water	✓
Raw Sewage	✓	Ozone Treatment	✓
Screened Sewage	✓	Irrigation	✓
Abrasive Slurries	✓	Buried Service	✓
Air Service	✓	Industrial Process Applications	✓
Corrosive Service	✓	Low Pressure Gas Service, Digester Gas	✓
Vertical Flow Up	✓	Throttling Service	✓
Vertical Flow Down	✓	Pump Check Service	✓
Non-Abrasive Slurries	✓	Modulating Service	✓

FEATURES

Vee Type Packing with Exclusive POP™ Shims	✓	Gear, Hydraulic and Power Actuation	✓
Integral Nickel Welded Seat	✓	Port areas for valves 4" and smaller ≥ 100%	✓
Exclusive Stainless Steel/Teflon Bearing Package	✓	Port areas for valves 6" - 16" ≥ 85%	✓
Grit-Guard™ Bearing and Packing Protector	✓	Port areas for valves 18" - 24" ≥ 80%	✓

CAM-CENTRIC PLUG VALVE SPECIFICATIONS

2 1/2" AND LARGER

SCOPE

- 1.1 This specification covers the design, manufacture, and testing of 2 1/2 in. (60 mm) through 36 in. (900 mm) Cast Iron Eccentric Plug Valves suitable for water or wastewater service with pressures up to 175 psig (1200 kPa).
- 1.2 Plug Valves shall be quarter-turn, non-lubricated, eccentric type with resilient faced plug.

CONNECTIONS

- 2.1 Flanged valves shall have flanges with drilling to ANSI B16.1, Class 125.
- 2.2 Mechanical Joint valves shall fully comply with ANSI/AWWA C111/A21.11.
- 2.3 Threaded valves shall have NPT full size inlets. The connection shall be hexagonal for a wrench connection.

DESIGN

- 3.1 Port areas of not less than 100% of pipe area shall be supplied on valves 4" (75 mm) and smaller, 85% on 16" (400 mm) and smaller, 80% on 18"-24" (150 mm - 600 mm), and 70% on 30" (800 mm) and larger.
- 3.2 The valve seat shall be a welded overlay of 99% pure nickel applied directly to the body on a pre-machined, cast seating surface and machined to a smooth finish.
- 3.3 Shaft seals shall conform to ANSI/AWWA C504 and consist of V-type packing in a fixed gland with an adjustable follower designed to prevent over compression of the packing and to meet design parameters of the packing manufacturer. Removable, slotted shims shall be provided under the follower flanges to provide for adjustment and prevent over tightening.
- 3.4 Permanently lubricated, radial shaft bearings shall be supplied in the upper and lower bearing journals. Thrust bearings shall be provided in the upper and lower journal areas.
- 3.5 Both the packing and bearings in the upper and lower journals shall be protected by a Grit-Guard™ shaft seal located on the valve shaft to minimize the entrance of grit into the bearing journal and shaft seal areas.

MATERIALS

- 4.1 The valve body and cover shall be constructed of ASTM A126 Class B cast iron for working pressures up to 175 psig (1200 kPa). The words "SEAT END" shall be cast on the exterior of the body seat end.
- 4.2 The plug shall be of one-piece construction and made of ASTM A126 Class B cast iron with a resilient facing per ASTM D2000-BG and ANSI/AWWA C504 requirements.
- 4.3 Radial shaft bearings shall be constructed of self-lubricating type 316 stainless steel. The top thrust bearing shall be Teflon. The bottom thrust bearing shall be Type 316 stainless steel. Cover bolts shall be corrosion resistant with zinc plating.

ACTUATORS

- 5.1 8 in. (200 mm) and smaller valves shall be equipped with a 2 inch square nut for direct quarter turn operation. The packing gland shall include a friction collar and an open position memory stop. The friction collar shall include a nylon sleeve to produce friction without exerting pressure on the valve packing.
- 5.2 When specified, 4 in. (100 mm) and larger valves shall include a totally enclosed and sealed worm gear actuator with position indicator (above ground service only) and externally adjustable open and closed stops. The worm segment gear shall be ASTM A536 Grade 64-45-12 ductile iron with a precision bore and keyway for connection to the valve shaft. Bronze radial bearings shall be provided for the segment gear and worm shaft. Alloy steel roller thrust bearings shall be provided for the hardened worm.
- 5.3 All gear actuators shall be designed to withstand, without damage, a rim pull of 200 lb (890 N) on the handwheel and an input torque of 300 foot pounds (406 N-m) for nuts.
- 5.4 Buried service actuators shall be packed with grease and sealed for temporary submergence to 20 feet of water. Exposed worm shafts shall be stainless steel.

OPTIONS

- 6.1 When specified, the port area shall have not less than 100% of pipe area.
- 6.2 Open and closed limit switches shall be provided on the actuator when specified.

MANUFACTURE

- 7.1 The manufacturer shall demonstrate a minimum of five (5) years experience in the manufacture of plug valves. The valves shall be proof of design tested in accordance with ANSI/AWWA C504. When requested, the manufacturer shall provide test certificates, dimensional drawings, parts list drawings, and operation and maintenance manuals.
- 7.2 The exterior of the valve shall be coated with a universal alkyd primer.
- 7.3 Valves shall be marked with the Serial Number, Manufacturer, Size, Cold Working Pressure (CWP) and the Direct and Reverse Actuator Pressure Ratings on a corrosion resistant nameplate.
- 7.4 Eccentric Plug Valves shall be Series 5800R (Flanged), 5800RT (Threaded) or 5900R (Mechanical Joint) as manufactured by Val-Matic® Valve & Mfg. Corporation, Elmhurst, IL. USA. or approved equal.

NOTE: CONSULT FACTORY FOR 1/2" - 2" SPECIFICATIONS.

VAL-MATIC®

