

End-Suction Pumps

Single Stage End-Suction Centrifugal Pumps

Weinman versatile, low cost pumps are engineered for use on most phases of liquid handling. These frame mounted, end-suction pumps are heavy duty, general purpose centrifugal pumps with heavy wall castings suitable for many commercial, industrial and municipal applications, such as condenser, chilled and hot water systems in HVAC, process secondary pumping, raw water intake and irrigation systems. High efficiency, robust case construction of cast iron and impeller construction of bronze makes these pumps an ideal selection for applications that require easy-to-maintain, reliable, long lasting pumps.

Heads to 260'
Flows to 2000GPM
Up to 60 HP
Up to 6" Discharge

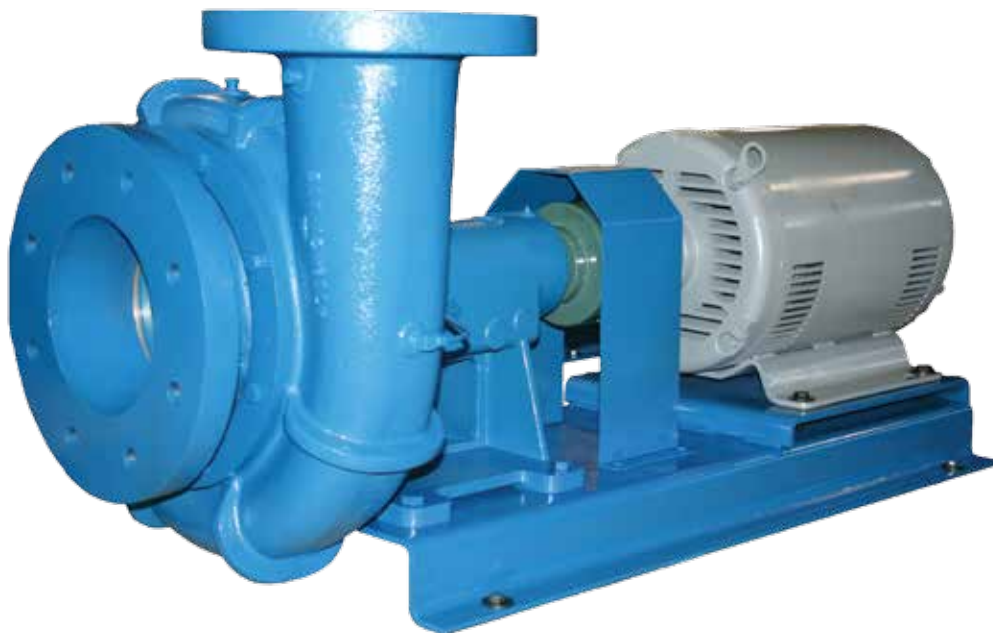

Dimensions

Motor Driven with NEMA motor frames

Bearing Frame Selection		
Size	1750 RPM	3500 RPM
2A	20 HP	40 HP
4A	60 HP	60 HP

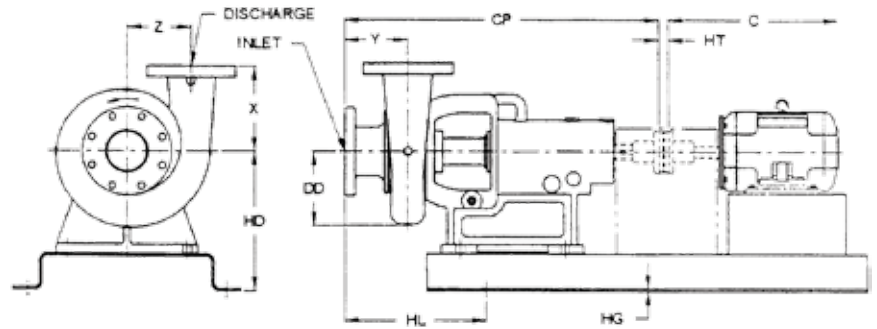
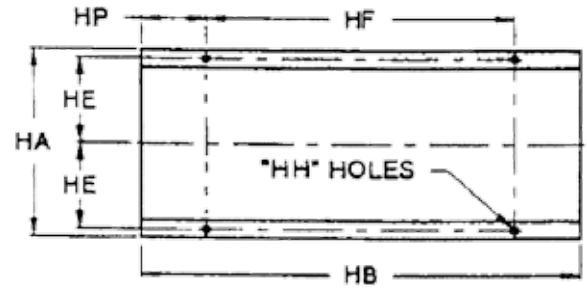
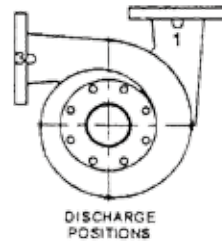

Performance Curves

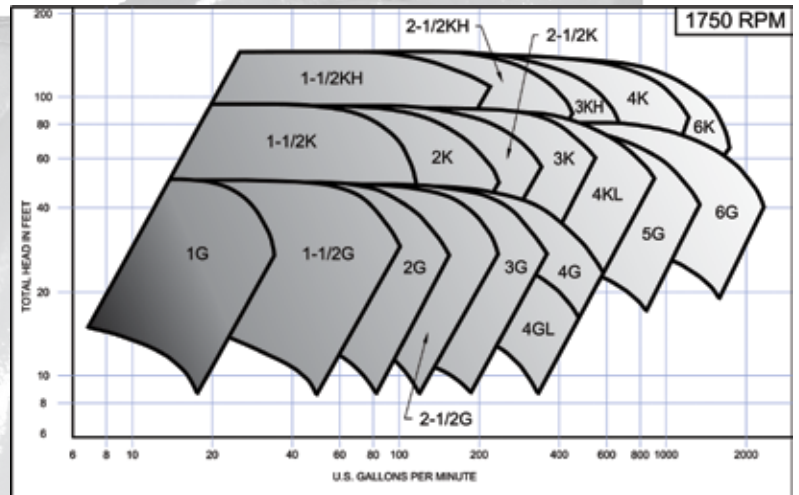
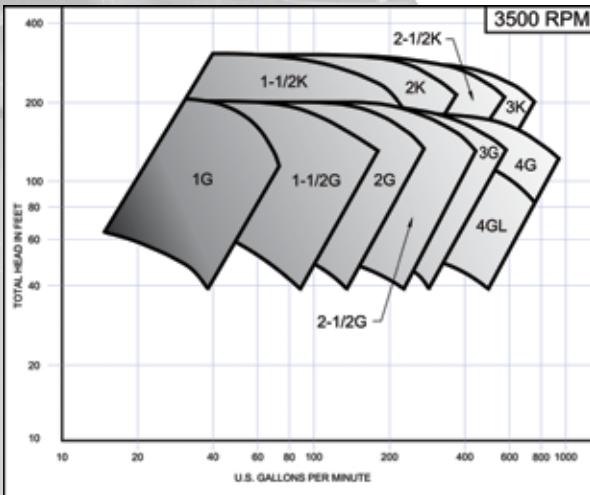

Principal Dimensions

No. 2A Bearing Frame

Connections - 125 Lb. Standard Flanges								
Pump	Disch.	Inlet	HL	X	Y	Z	CP	DD
1G2A	1	1¼	10 ⁷ / ₁₆	5	4¼	4½	19 ¹⁵ / ₁₆	5
1½G2A	1½	2	9 ⁵ / ₈	5¼	5¼	4¾	19 ¹ / ₈	5 ⁵ / ₈
1½GT2A	1½	3	11 ³ / ₈	5¼	5¼	4¾	20 ⁷ / ₈	5 ⁵ / ₈
1½K2A	1½	2	10 ¹ / ₁₆	6¼	3¾	5¼	19 ⁹ / ₁₆	7¼
1½KH2A	1½	2	11 ⁵ / ₁₆	7½	4¾	6¼	19 ¹¹ / ₁₆	8
2G2A	2	3	11¼	5½	4½	4½	20 ³ / ₄	5 ¹ / ₁₆
2K2A	2	3	10 ¹ / ₁₆	6¾	3 ³ / ₈	6	19 ⁹ / ₁₆	7½
2½G2A	2½	3	10 ³ / ₁₆	6¼	4	4½	19 ¹¹ / ₁₆	6 ¹ / ₁₆
2½K2A	2½	3	10 ⁵ / ₈	7	4	6¼	19 ⁷ / ₈	7 ¹¹ / ₁₆
3G2A	3	4	11	6	4 ⁵ / ₈	4 ⁷ / ₈	20 ¹ / ₂	6 ⁵ / ₈
3K2A	3	4	10 ⁵ / ₈	7 ⁹ / ₁₆	4½	6½	30 ³ / ₈	8 ⁷ / ₈
4G2A	4	5	11¼	6¾	4 ¹¹ / ₁₆	5½	20 ³ / ₄	7 ³ / ₈
4GL2A	4	5	11¼	6¾	4 ¹¹ / ₁₆	5½	20 ³ / ₄	7 ³ / ₈

No. 4A Bearing Frame

Connections - 125 Lb. Standard Flanges								
Pump	Disch.	Inlet	HL	X	Y	Z	CP	DD
1½KH4A	1½	2	11¼	7½	4¾	6¾	25½	8
1½K4A	1½	2	11 ¹ / ₁₆	6½	3 ⁷ / ₁₆	5¾	25 ⁵ / ₁₆	7¼
2K4A	1½	2	11 ⁵ / ₈	6¾	3 ³ / ₈	6	25 ⁵ / ₈	7½
2½G4A	1½	2	11 ⁵ / ₈	7¾	4	4½	25 ⁵ / ₈	6 ¹ / ₁₆
2½K4A	2	3	11½	7	4	6¼	25¾	7 ¹¹ / ₁₆
2½KH4A	2	3	11½	7¾	4¼	7½	25¾	9 ⁷ / ₁₆
3G4A	2½	3	12 ³ / ₁₆	7¾	4 ⁵ / ₈	4 ⁷ / ₈	26 ⁷ / ₁₆	6 ¹ / ₁₆
3K4A	2½	3	11 ⁹ / ₁₆	7¼	4½	6½	25 ⁵ / ₁₆	8 ¹ / ₈
3KH4A	3	4	11 ⁵ / ₈	8½	4½	7¾	26½	9 ³ / ₈
4G4A	3	4	12 ³ / ₁₆	7¾	4 ¹¹ / ₁₆	5½	26 ⁵ / ₈	7 ³ / ₈
4GL4A	4	5	12 ³ / ₁₆	7¾	4 ¹¹ / ₁₆	5½	26 ⁵ / ₈	7 ³ / ₈
4K4A	4	5	11 ⁵ / ₈	10	5	8 ³ / ₈	26 ⁵ / ₈	10 ³ / ₄
4KS4A	4	5	12 ⁷ / ₁₆	8 ⁵ / ₈	5½	6¾	26 ¹¹ / ₁₆	8 ⁷ / ₈
4KL4A	4	5	12 ⁷ / ₁₆	8 ⁵ / ₈	5½	6¾	26 ¹¹ / ₁₆	8 ⁷ / ₈
5G4A	5	6	13 ⁷ / ₁₆	8½	6	7¼	27 ¹¹ / ₁₆	9 ¹⁵ / ₁₆
6G4A	6	8	14	9½	6½	8½	28¾	11 ⁷ / ₁₆
6K4A	6	8	13 ¹³ / ₁₆	12	6½	9	28 ¹ / ₁₆	11 ⁹ / ₁₆

No. 2A Bearing Frame

Horsepower - 3 PH				Motor Frame	Base No.	C		HA	HB	HD	HE	HF	HG	HH	HL	HP	HT
TE 3500	DP 3500	TE & DP				DP	TEFC										
		1750	1150														
1/3	1/3	1/4, 1/3	-	48	010031	9.63	10.75	15½	30	10½	6¾	22	¼	¾	4	10.44	5 ⁵ / ₈
1/2	1/2	1/2	-	56	010029	11.25	13.38									9.63	3 ³ / ₈
¾, 1	¾, 1	¾	-	56	010029	11.25	13.38									11.38	3 ³ / ₈
1½	1½	1	¾	143T	010030	12.81	11.50									10.06	9 ¹ / ₁₆
2	2	1½	1	145T	010030	12.81	11.50									11.31	9 ¹ / ₁₆
-	3	2	-	145T	010030	12.81	11.50									11.31	9 ¹ / ₁₆
3	5	3	1½	182T	010032	13.63	16.13									11.25	5 ⁵ / ₈
5	7½	5	2	184T	010032	13.63	16.13									10.06	5 ⁵ / ₈
7½	10	7½	3	213T	010033	15.50	18.63									10.19	7 ³ / ₈
10	15	10	5	215T	010033	17.00	20.13									10.38	7 ³ / ₈
15	20	15	-	254T	010034	20.31	23.75	11.00	1								
20	25	20	-	256T	010034	22.06	25.50	10.88	1								
25	30	-	-	284TS	010035	22.00	24.75	11.25	1								
30	40	-	-	286TS	010035	23.50	26.25	11.25	1								

No. 4A Bearing Frame

Horsepower - 3 PH				Motor Frame	Base No.	C		HA	HB	HD	HE	HF	HG	HH	HL	HP	HT
TE 3500	DP 3500	TE & DP				DP	TEFC										
		1750	1150														
3	5	3	1½	182T	010036	13.63	16.13	19	36	13	8½	28	5/16	¾	4	11.25	13 ¹³ / ₁₆
5	7½	5	2	184T	010036	13.63	16.13									11.06	13 ¹³ / ₁₆
7½	10	7½	3	213T	010037	15.00	18.63									11.13	9 ¹ / ₁₆
10	15	10	5	215T	010037	17.00	20.13									11.13	9 ¹ / ₁₆
15	20	15	7½	254T	010038	20.31	23.75									11.50	15 ¹⁵ / ₁₆
20	25	20	10	256T	010038	22.06	25.50	11.50	15 ¹⁵ / ₁₆								
25	-	25	15	284T	010039	23.38	26.13	12.19	1								
-	-	30	20	286T	010039	24.88	27.63	11.56	1								
25	30	-	-	284TS	010040	22.00	24.75	11.88	15 ¹⁵ / ₁₆								
30	40	-	-	286TS	010040	23.50	26.25	12.38	15 ¹⁵ / ₁₆								
-	-	40	-	324T	010041	25.97	29.69	11.88	1¼								
-	-	50	-	326T	010041	27.44	31.19	12.44	1¼								
40	50	-	-	324TS	010042	24.44	28.19	13.44	1								
50	60	-	-	326TS	010042	25.94	29.69	14.00	1								
60	-	60	-	364TS	010043	29.56	30.00	24½	48	11½	40	13.81	1				

Dimensions approximate. Not for construction.

Features & Benefits

Economy Today... tomorrow... anytime... Weinman Single Stage, End-Suction Centrifugal Pumps are your most economical buy. Lower in initial cost, they require a minimum of maintenance and operating expenses over the years.

Quality Construction Every detail of precision workmanship plus finest materials contribute to Weinman's high standard of quality construction... your assurance of continuous, reliable pumping service.

Modern Design Developed by experienced pump engineers

thoroughly familiar with actual service conditions, Weinman Pumps feature the most modern and scientific hydraulic and mechanical design.

Efficiency Single Stage, End-Suction Pumps, particularly in smaller sizes, are more efficient than double suction pumps. Mechanical and hydraulic losses are reduced, resulting in higher operating efficiency.

Compactness Weinman Single Stage, End-Suction Pumps are particularly useful where installation space is limited.

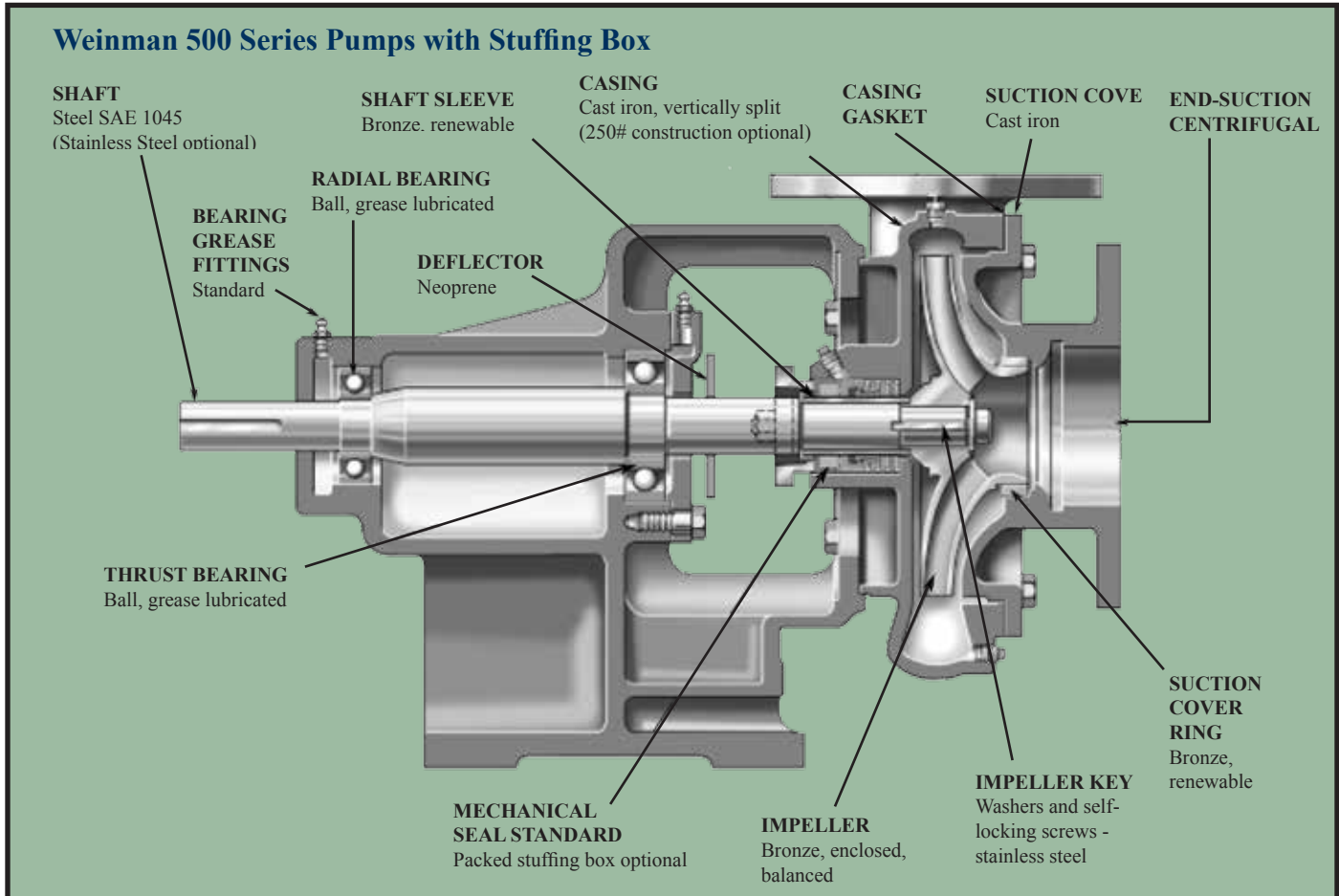

A Crane Co. Company

PUMPS & SYSTEMS

Crane Pumps & Systems
420 Third Street
Piqua, Ohio 45356
(937) 778-8947
Fax (937) 773-7157
www.cranepumps.com

Crane Pumps & Systems Canada
83 West Drive
Brampton, Ont. Canada L6T 2J6
(905) 457-6223
Fax (905) 457-2650

© 2013 Crane Pumps & Systems, Inc.
A Crane Co. Company
Printed in U.S.A.
W500BRO - Rev. B (5/13)



brands you trust.

BARNES

burks

DEMING®

WEINMAN®



PROSSER®